

10,000 litre Collection Well - Installation Manual

10,000 litre Collection Well Order code CW10000 Drawing HCT43D 51

Tank weight
4,800kg

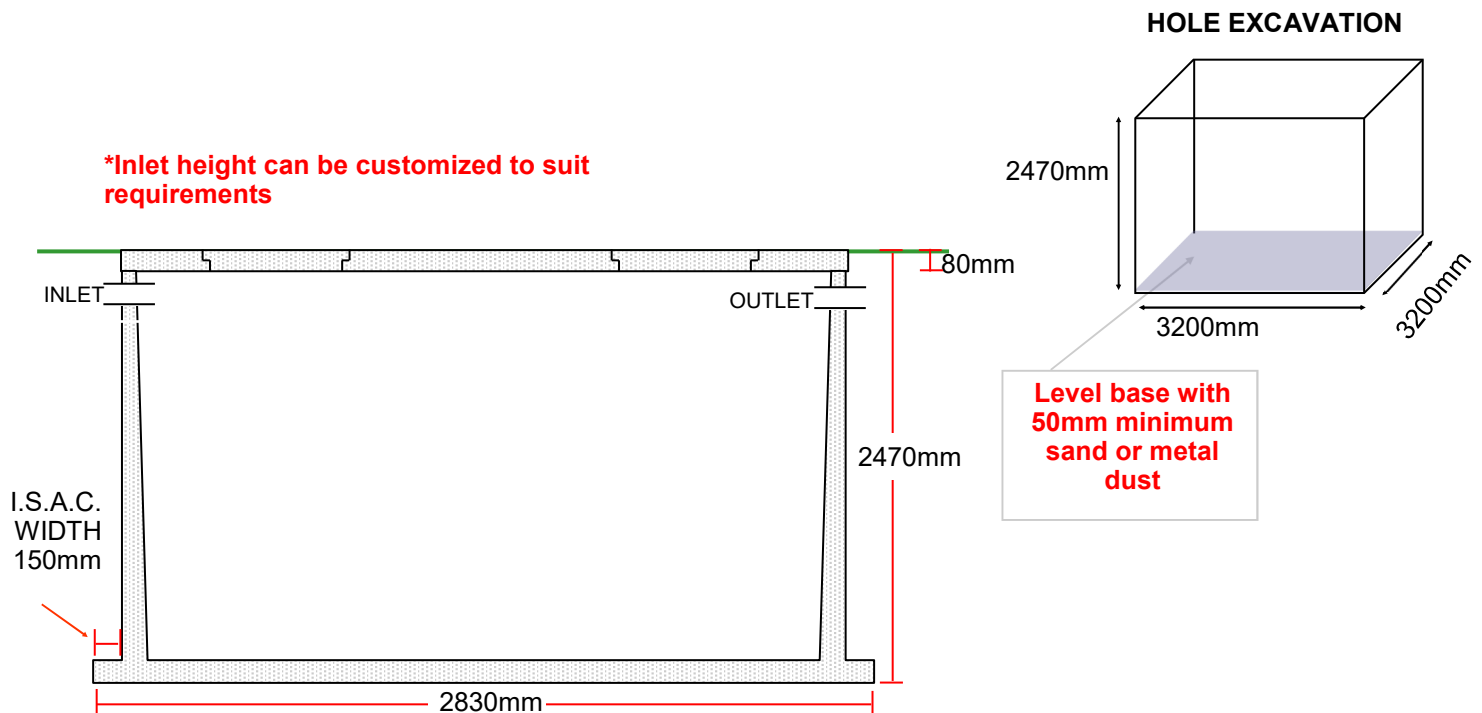

1. Tanks with 80mm lid must be backfilled to within 200mm from top of lid all around tank. Warranty void if not backfilled correctly.
2. Excavation of hole to drawing specifications, allowing 50-100mm above ground level as shown. Lid depth 80mm.
3. Excavation to be minimum 2.2 metres from dwelling to prevent subsidence beneath footings unless otherwise authorised by Local Government Authorities.
4. Install tank in hole with level bottom, using minimum 50mm metal dust aggregate base. Warranty void if not installed according to installation manual.
5. Connect pipework to tank in accordance with AS/NZS 3500.2.
6. Tanks have a 100mm DWV pipe protruding 50mm from tank wall to allow connection of 100mm Inspection Opening and sewer pipe from dwelling.
7. It is recommended to pour concrete collar around tank base using approximately 2 metres of concrete to prevent lifting of tank in saturated ground.
8. Backfill tank.
9. Fill tank with minimum 4,000 litres water to prevent lifting of tank.
10. It is the plumbers or owners responsibility to provide all weather access for delivery truck to the excavated hole. **Ensure access is free of power lines and overhanging trees.**
11. Location of tank – avoid storm water run off areas.
12. When backfilling tank ensure no large rocks in excess of 200mm enter hole. Any damage to tanks, e.g. large rocks or machinery damage, during backfilling is the responsibility of the contractor and/or owner and is not covered by warranty.
13. Standard lids are designed for pedestrian traffic only and must not be covered by any fill materials.
14. Lids are sealed at factory using sand and cement mix or an approved sealant.
15. Access covers, due to their mass, are self sealing.
16. Tanks are not to be emptied in wet weather. Additional downward force may be required in areas of high water table.
17. All septic tanks and collection wells are manufactured in accordance with AS/NZS1546.1:2008.